

# 8th AVENUE IMPROVEMENTS, 25th STREET - 27th STREET

LEGEND	
	EXISTING RIGHT-OF-WAY
	EXISTING CURB AND GUTTER
	PROPOSED CURB AND GUTTER
	EXISTING EDGE OF BUILDING
	SIDEWALK PAVING
	CONCRETE PAVING
	DECORATIVE PAVING

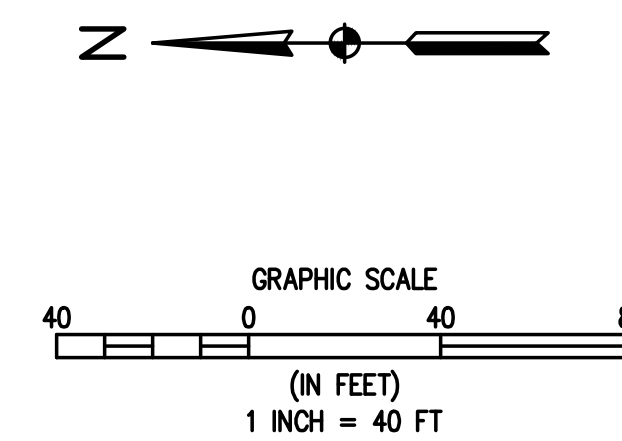
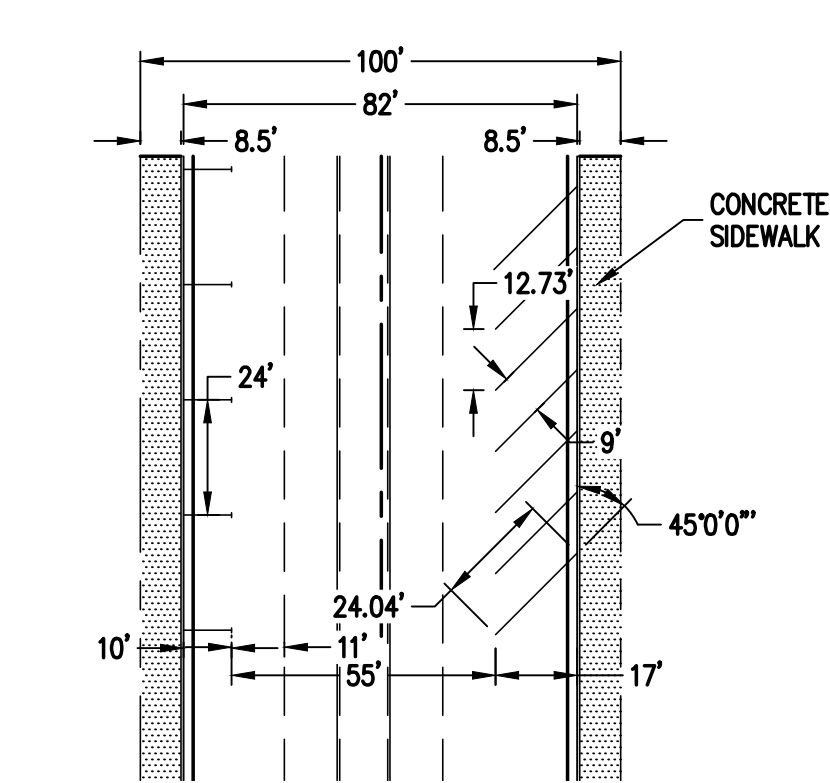

1 STREET PLAN SECTION (TYP)

**BASELINE**  
 Engineering - Planning - Surveying  
 1850 FORD STREET • GOLDEN, COLORADO 80401  
 P. 303.940.9666 • F. 303.940.9665 • www.baselinecorp.com

DESIGNED BY	XXX
DRAWN BY	XXX
CHECKED BY	XXX
DATE	
PREPARED BY	
REVISION DESCRIPTION	

**TOWN OF GARDEN CITY**  
 WELD COUNTY  
**8TH AVENUE**  
 CONCEPT IMPROVEMENT PLANS

GARDEN CITY  
 PREPARED UNDER THE DIRECT SUPERVISION OF

FOR AND ON BEHALF OF	BASELINE CORPORATION
INITIAL SUBMITTAL	XX/XX/XX
DRAWING SIZE	24" X 36"
SURVEY FIRM	XX/XX/XX
SURVEY DATE	XX/XX/XX
JOB NO.	C00000
DRAWING NAME	15269 - CIVIL.dwg
SHEET	1 OF 2

M:\co-15269 - Garden City\Drawings\15269 - CIVIL.dwg, 6/28/2016 3:26:31 PM, Joy Davis



# 8th AVENUE IMPROVEMENTS, 27th STREET - 28th STREET

**LEGEND**

- EXISTING RIGHT-OF-WAY
- EXISTING CURB AND GUTTER
- PROPOSED CURB AND GUTTER
- EXISTING EDGE OF BUILDING
- SIDEWALK PAVING
- CONCRETE PAVING
- DECORATIVE PAVING

**BASELINE**  
 Engineering · Planning · Surveying  
 1850 FORD STREET • GOLDEN, COLORADO 80401  
 P. 303.940.9666 • F. 303.940.9668 • www.baselinecorp.com

DESIGNED BY: XXX  
 DRAWN BY: XXX  
 CHECKED BY: XXX

REVISION DESCRIPTION	DATE	PREPARED BY

TOWN OF GARDEN CITY  
 WELD COUNTY  
 8TH AVENUE  
 CONCEPT IMPROVEMENT PLANS

GARDEN CITY  
 PREPARED UNDER THE DIRECT SUPERVISION OF

FOR AND ON BEHALF OF  
 BASELINE CORPORATION  
 INITIAL SUBMITTAL: XX/XX/XX  
 DRAWING SIZE: 24" X 36"  
 SURVEY FIRM: SURVEY DATE: XX/XX/XX  
 SURVEY FIRM: SURVEY DATE: XX/XX/XX  
 JOB NO.: C0XXXX  
 DRAWING NAME: 15269 - CIVIL.dwg  
 SHEET 2 OF 2

C2

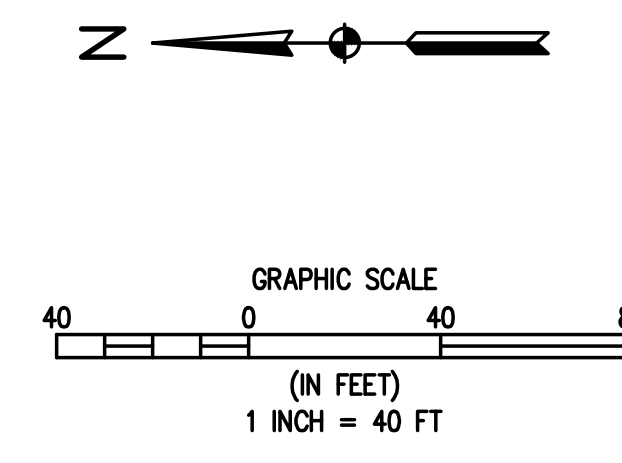
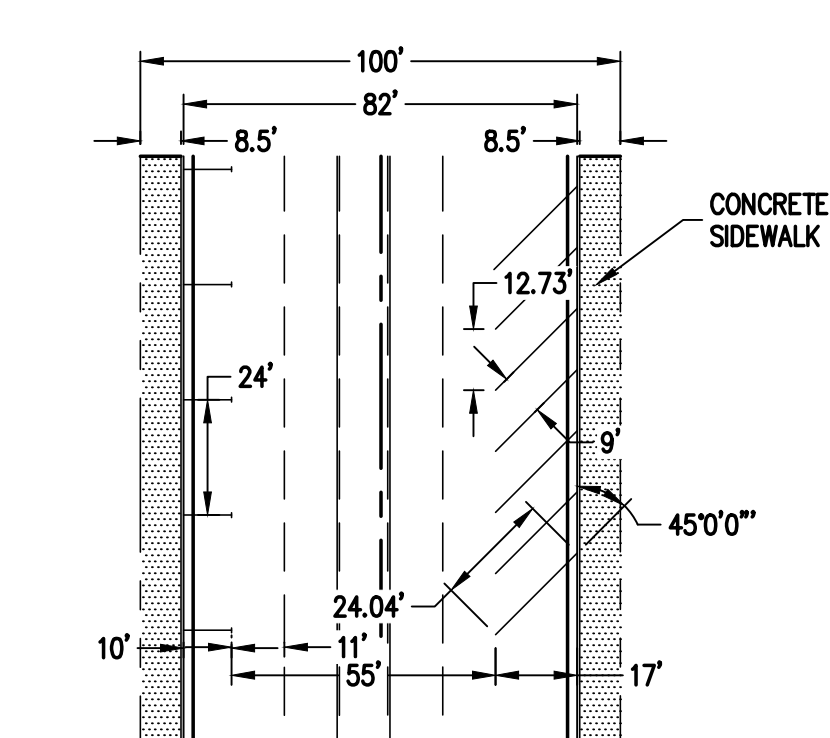

1 STREET PLAN SECTION (TYP)

M:\co-15269 - Garden City\Drawings\15269 - CIVIL.dwg, 6/28/2016 3:27:33 PM, Joy Davis